



SECTION I

HOW TO BUILD A CHIMNEY SOLAR DRYER

Steps to build a chimney solar dryer using low-cost, easily available materials

FOUR MAIN COMPONENTS OF THE CHIMNEY SOLAR DRYER

The dryer design has four elements:

1. A drying table covered with black plastic or fabric.
2. A chimney covered with clear plastic with an opening at the drying table.
3. Mesh-covered drying trays to hold the produce.
4. Clear polyethylene plastic film that covers the trays and the drying table and is sealed to the chimney.



INSTRUCTIONS

Although this is a relatively simple structure, working with an experienced builder is recommended. Alternatively, if you do not have access to a carpenter or skilled builder, the dryer can be built with a team of 4-6 people in about half a day, with a team of 2-3 constructing the table and chimney, while 2-3 people work on the trays simultaneously.

MATERIALS

Materials needed to build the dryer include wood, clear polyethylene plastic, black plastic or fabric, and food-grade mesh. Quantities may vary depending of the size of your chimney solar dryer. Materials above are calculated based on actual dimensions. *It is suggested to buy 10 percent extra material to account for minor errors or other unforeseen issues.*

Four main components to the chimney solar dryer, clockwise from top left: a drying table, a chimney, mesh trays, and clear film to cover the drying table.

MATERIALS NEEDED TO BUILD THE CHIMNEY SOLAR DRYER

Item description	Label in figures	Number of pieces	Size (W x H x L)
Combined wood for drying table and chimney frames			(total: 56.09 m)
Wood for table frame and chimney frame	A	23	3 cm x 3 cm x 54 cm
	B	4	3 cm x 3 cm x 2.8 m
	C	4	3 cm x 3 cm x 4 m
	D	8	3 cm x 3 cm x 74 cm
Diagonal stabilization boards for drying table and chimney	E	3	3 cm x 3 cm x 95 cm
	F	2	3 cm x 3 cm x 1.6 m
	G	3	3 cm x 3 cm x 1.5 m
Combined wood for trays			(total: 24 m)
Wood for 10 trays	H	40	2 cm x 4 cm x 60 cm
Center support and lateral poles			(total: 12 m)
Wood or bamboo poles	I	3	Minimum length 4 m
Additional wood for support and attachment			(total: 11.6 m)
Pole support	J	2	2 cm x 15 cm x 30 cm
Pole support shelves	K	2	2 cm x 15 cm x 64 cm
Wood strips	L	2	2 cm x 4 cm x 4 m
Plastic covering			
Clear plastic for chimney cover		1	2.2 m x 3 m
Clear plastic for drying table cover		1	4 m x 3 m
Black plastic or fabric to cover drying table front, top, and sides (thicker is better)		1	6 m x 2.7 m
Food grade plastic or stainless steel mesh			
Mesh for 10 trays		10	60 cm x 60 cm

In this manual, all instructions are for a 4-meter long table and a 2.8-meter tall chimney. This design uses 60 cm x 60 cm trays, because the table frame is 60 cm wide, and you can fit 5 trays (or 10 trays in stacks of 2) on a 4-meter long table.

ESSENTIAL FEATURES

While the dryer dimensions can be changed to various sizes and preferences, several key features should **NOT** be changed:

1. The chimney and the table should be the same width.
2. The height of the chimney, as measured from the top of the table, should be 2 meters tall.
3. Seal the table to the chimney with the clear plastic covering the table, otherwise airflow above and below the product will be dramatically reduced due to air leakage.
4. Ensure a small headspace in the tunnel above the product (about 5 cm) to maintain airspeed in the tunnel.
5. For more efficient drying, avoid using milky colored polyethylene (PE) or polyvinyl chloride (PVC) plastic for covering the drying table. Thicker plastic will prevent ripping early. We recommend around 6mil or 0.15mm thick clear plastic.
6. The front of the table, below the opening to the drying tunnel, needs to be covered to prevent airflow below the top of the table versus through the drying tunnel. Do not block or impede airflow at the opening of the drying tunnel.

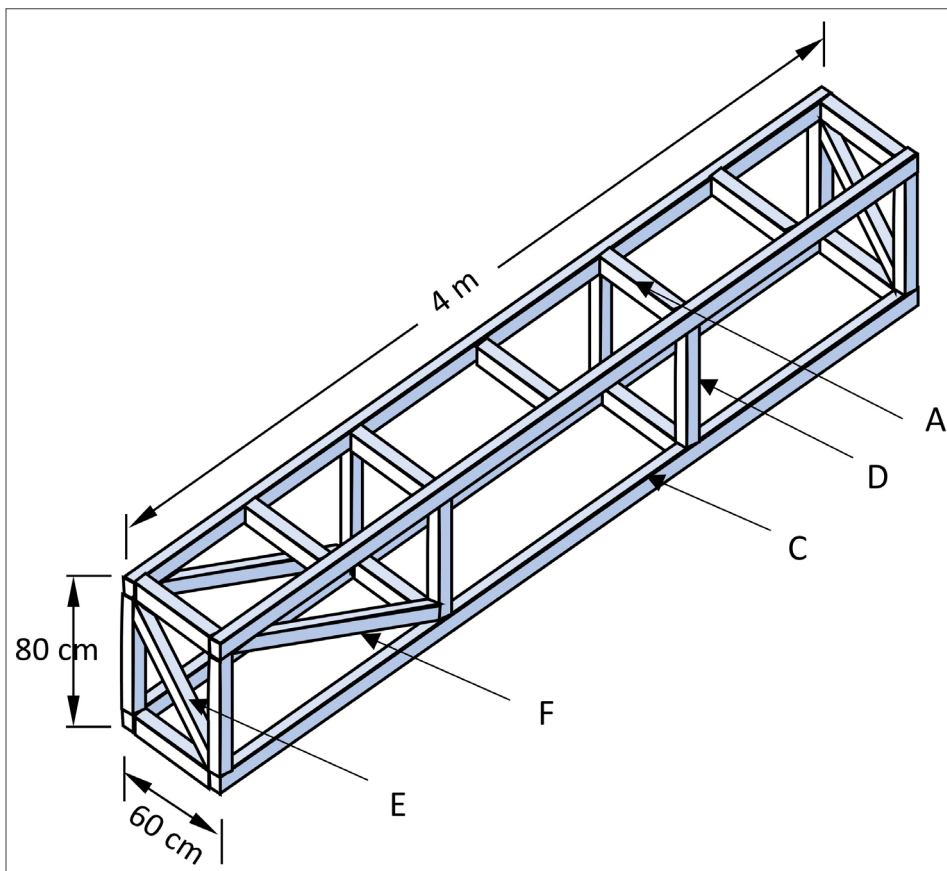

Figure 2. Wood frame for the table

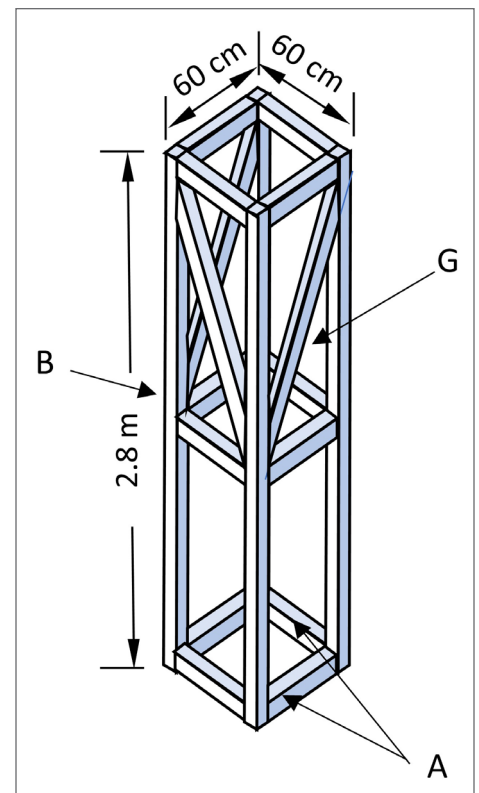

Figure 3. Wood frame for chimney

SITE SELECTION AND DRYER ORIENTATION

A full-sized dryer, using the design in this manual will be 4 m long. You will need enough flat area with good sun exposure to take full advantage of the dryer. The opening of the dryer should always face the equator to maximize sun exposure. In the northern hemisphere, this means the opening of the dryer should face south, with the chimney in the north. In the southern hemisphere, the chimney would be in the south, with the opening of the dryer facing north. Select an area where trees do not shade the dryer. Make sure the ground is cleared of tall grasses, and the area is free from roaming animals.

BUILD THE FRAME FOR THE TABLE

- The drying table is the core of the dryer; it holds the trays and is attached to the chimney (Fig. 2).
- The frame can be built from scratch or you can use an existing table or other similarly shaped structure.
- The table height can be adjusted according to preference and should be at a comfortable height to work on the product trays. We choose to use 80 cm for the height of the table in this manual.
- For a 4-m long dryer, the table frame will be 4 m long, 80 cm tall and 60 cm wide.
- Using the materials listed in the table, build a sturdy wood frame that can support the weight of the trays when filled with product. We like to use the 54 cm pieces (shown in Fig. 2 as A) as slats across the top to support the trays.
- Once the table frame is built, then stretch the black, non-woven fabric or plastic sheet over the top and all sides of the frame except the bottom, and secure to the frame with staples.
- Attach two narrow strips of wood to the drying table on top of the black material to hold trays above the table surface.

BUILD THE CHIMNEY

- The chimney is made from four planks of wood (shown in Fig. 3 as B).
- Make sure that the chimney is tall enough so that it rises 2 m (200 cm) above the top of the drying table (Fig. 3). For instance, if your drying table is 80 cm tall, then your chimney height should be 2.8 m (280 cm) tall.
- The chimney must be as wide as the drying table.
- Cover the whole chimney frame in clear plastic, securing the plastic to the frame with staples, leaving the top open.

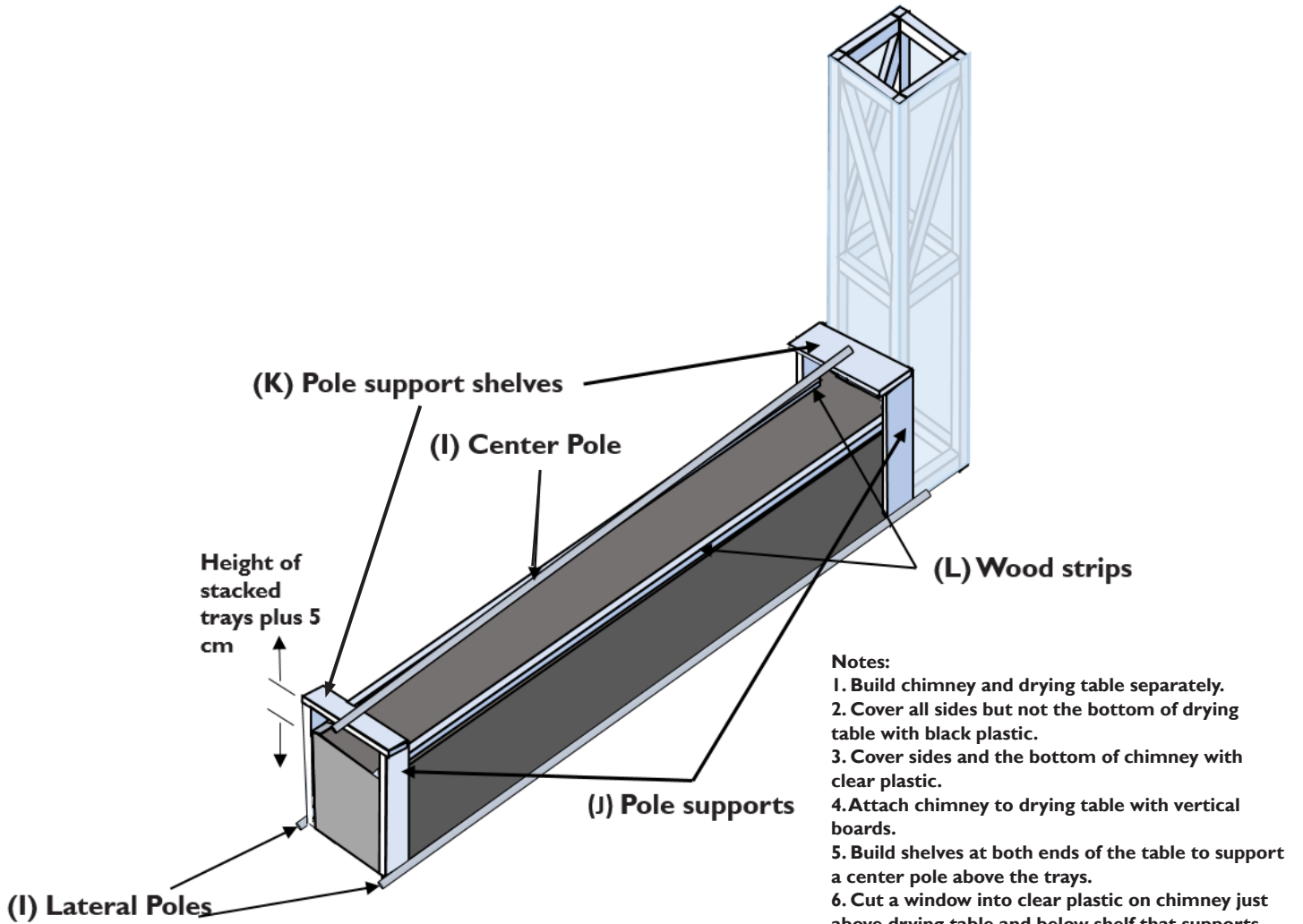

Figure 4. Sketch of the chimney attached to the drying table

PUT THE PIECES TOGETHER

- Attach the table to the chimney with two vertical boards (shown in Fig. 4 as J) and screws. Create a shelf above the table by using these two “pole support” wood pieces (shown in Fig. 4 as J) and the two “pole support shelves” (shown in Fig. 4 as K). This should be done on both ends of the table. The height of the space under the shelves should be approximately 5 cm above the top of two stacked trays
- Cut an opening in the chimney in the shape of a rectangle, above the drying table and below the shelves, to help create a tunnel for air to flow over the product, through this opening, and out the chimney.
- Place a wood pole (shown in Fig. 4 as I) on top of the shelf as support for the clear plastic that will cover the drying table.



Build a shelf at the opening of the dryer set to be about the height of two trays stacked plus 5 cm above the table top to support the center pole over which the clear plastic will be draped.



Photos from left: Build a second shelf at the chimney end of the drying table matching the same height. Cut a rectangular window into the chimney plastic and attach the edge of the plastic to the shelf. Place bamboo or wood pole (center pole) across the top of the shelves, which will tent the plastic above the trays when in use.

BUILD THE TRAYS

- Use the 60 cm long wood strips to make the trays (shown in Fig. 5 as H). Each tray will use 4 pieces (60 cm), one on each side.
- By joining the wood stacked as shown in Fig. 5, you will use less wood and more importantly, get good airflow.
- Pre-cut the mesh and staple it to two wood strips opposite each other, pull them apart, tightening the mesh, and secure the other two strips of wood, assuring the corners are at right angles and the overall tray is square.
- Staple along each edge to secure the mesh to the wood. Trim the edges of the mesh if needed so that edges are smooth and will not rip the plastic during use.

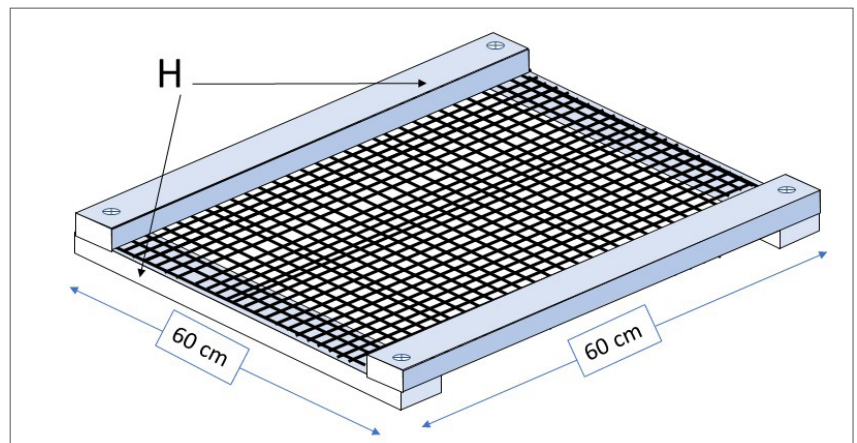
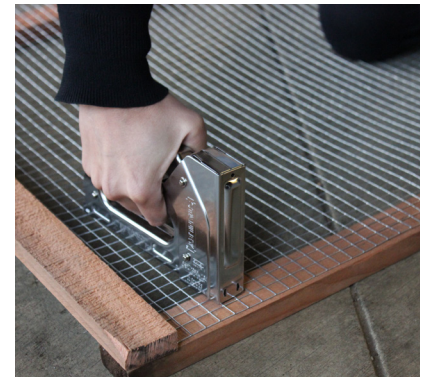
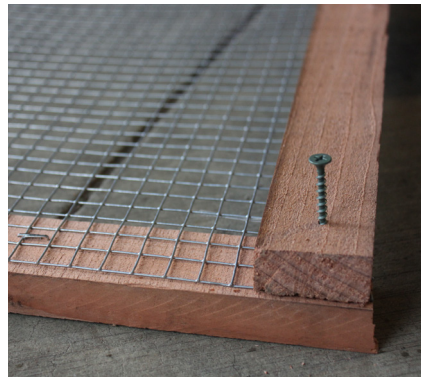

Figure 5. Drying tray

BEFORE YOU COVER THE DRYER WITH PLASTIC

- Make sure that the desired number of trays fits on the frame; trays can be stacked one or two high.
- If the trays are stacked, make sure that the product on the bottom tray does not touch the tray above.
- Position the 4 m wood or bamboo center pole on support shelves just above the top trays to hold the plastic above the product (Fig. 6).



Pre-cut the mesh. Join the wooden edges of the tray with a nail or screw. Staple the mesh to the wood sides of the tray. Trim any sharp edges of the mesh to prevent ripping the dryer's plastic during use.

CREATING AN EFFECTIVE DRYING TUNNEL DURING OPERATION

- Drape the clear plastic over the center support pole and the table.
- After the clear plastic has been draped over the center support pole and trays of product, you need to secure the length of the plastic to the ground with two lateral poles in order to take slack out of the plastic on the sides of the drying table.
- To seal the plastic at the chimney, tuck the clear plastic tightly over the support shelf and two vertical boards (pieces J in Fig 4.) securing the table to the chimney. This prevents air from going around the drying table and not entering the chimney. To seal the plastic to the chimney end of the dryer and along the sides of the table, use any combination of the following: wrapping a bicycle tire inner tube around the shelf area; using bricks; scrap wood; tape or Velcro.



A bicycle inner tube around the shelf is a solution for making sure the clear plastic at the chimney is tightly sealed against the sides and top of the shelf. Use bricks to secure the poles to the side and make sure there is no slack in the clear plastic cover along the table sides.

TIPS AND TROUBLESHOOTING

LIMITED AIRFLOW ACROSS THE DRYING TRAYS

The height of the pole above the trays should not be more than 5 cm or it will reduce the airspeed in the tunnel. Also ensure the clear plastic is sealed tightly to the wood shelf above the opening to the chimney and sealed tightly to the drying table near the chimney. There are a few simple options to check airflow in the dryer:

- Observe the plastic around the table is slightly suctioned inwards.
- Hang small strips of tissue paper (0.5 x 7.5 cm) from the pole in the middle of the drying table. When air is flowing, these strips will move with the flowing air.
- Puff smoke into the opening of the dryer and see if the smoke goes across the product and up and out the chimney.
- “Nose check” - at the opening at the front of the table you should not notice warm air or strong smell from the product coming out of the dryer.

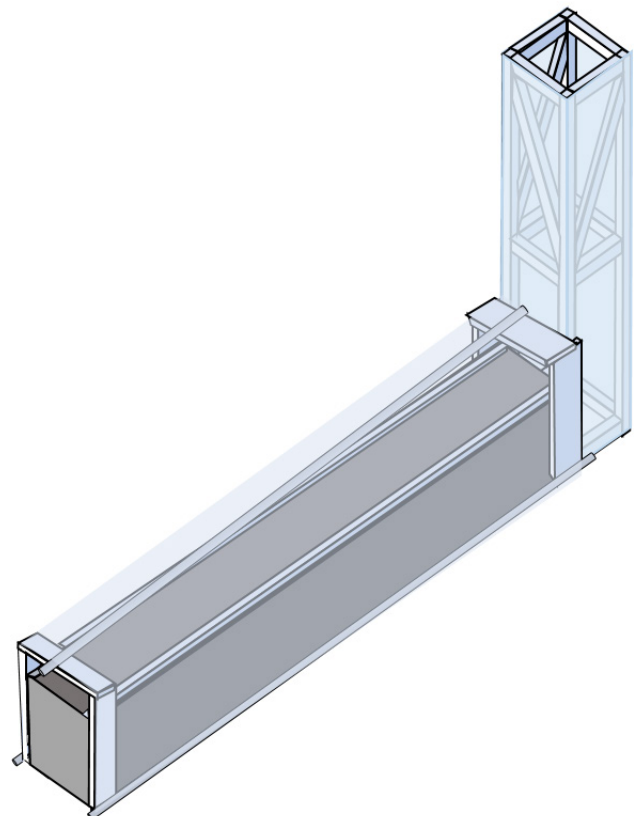

Figure 6. Clear plastic wrapped around the table

TRAYS ORIENTED INCORRECTLY ON THE DRYING TABLE

The airflow above and below the tray is imperative; orient the trays accordingly so that edges do not block airflow. If the products on the lower tray are touching the tray above, they will block airflow and products will take longer to dry. Overloading the trays with fruits and vegetable can also slow the rate of drying.

BLOCKAGE AT THE FRONT OF THE DRYING TABLE

Ensure that the front of the dryer is open and unobstructed (i.e. that the clear plastic on the drying table is not covering the tunnel entrance) so that air can flow into the dryer. A mesh screen can be used to cover the air inlet to keep animals out, if needed, but only do this if necessary as it may slow airflow. Insects are usually not a problem, as they are not attracted to the fruit during drying due to the airflow and resulting lack stagnant odor.



Correct tray orientation



Incorrect tray orientation

REMOVE THE SHARP EDGES

Make sure to remove all sharp wood or metal edges on the pole support shelves and trays before putting the clear plastic over the drying table. This includes trimming down the sides of the metal mesh on the drying trays.

WINDY CONDITIONS

Due to the chimney height, the chimney dryer can be damaged in windy conditions. To prevent the chimney dryer from tipping over or plastic being damaged, precautions should be taken.

Solutions for windy conditions while dryer is in use include:

- Use guy wires or ropes attached at the top of the chimney and staked to the ground.
- Use stakes in the ground and attach them directly against the sides of the table and chimney for bracing.

Solutions for windy conditions while dryer is not in use include:

- Remove the chimney from the table when the dryer is not in use.
- Lay the entire structure on its side.
- Store the clear plastic used for covering the table and trays indoors to prevent weather damage.

MULTI-DAY DRYING AND STORAGE

Some products require more than one day of drying. Where possible, bring the product indoors overnight, especially in areas of high humidity, which can prevent re-wetting of the drying product in moist, night air.

ADAPTIVE DESIGNS

To overcome difficulties procuring materials, to improve dryer ergonomics, or to extend the longevity of the dryer, collaborators have introduced adaptations to the dryer design that have been recognized as effective.

- **Center pole supporting plastic is sagging or rolling around:** Build an additional pole support shelf (dimensions can match J and K in the material table) in the middle of the table to help hold up the center pole under the clear plastic covering the drying table (images A and B). Add small blocks of wood on either side of the center pole on each shelf to keep the center pole from rolling around (see image C).
- **Challenges sourcing a 4m long pole to support the plastic table cover:** One or two ropes secured at the pole support shelves (see parts labeled K in Figure 4) at each end of the table and pulled taut is an alternative means to provide sufficient support for the plastic covering the drying table.
- **Minimize readjustments to plastic covering the drying table:** Securing the plastic at the base on one of the lateral table sides of the dryer permanently and then opening only from the free side reduces the effort required to reposition the plastic after it is removed to add or remove product (image D).
- **Reduce tears in plastic:** Using irrigation drip tape along edges where plastic is secured to the wood reduces probability of tears at the contact point of the staples and the plastic (image E).
- **Moving the dryer:** Construct a “handle” by securing a wooden board on the back of the chimney (image F).



Left and top right: An additional pole support in the center of the table to reduce sagging. Bottom right: small blocks of wood on the center pole support shelves prevents pole from rolling.

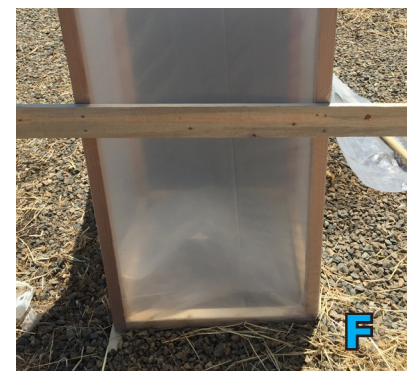

Above: securing the clear plastic covering to one side can help reduce tears. Top right: drip tape placed along edges with staples reduces rips at staple points. Bottom right: a piece of wood secured at the back of the chimney can be used to help with moving the chimney solar dryer if necessary.