

New chimney dryer design results in faster drying due to higher air speeds

A.I. Deltsidis¹, A. Mukherjee¹, M.R. Islam¹, L. Wheeler², E. Mitcham¹, J. Thompson¹ and M.S. Reid¹

¹Horticulture Innovation Lab, University of California Davis, CA, USA; ²Sonora Pacific Group, Lone Pine, CA, USA.

Abstract

Food losses in the developing world range between 30 and 50%, contributing to food insecurity and inefficient resource allocation. Many agricultural products, particularly fruit and vegetables, have production peaks when, despite high product quality, prices are typically low because supply is greater than demand. The oldest and most effective method of food preservation in resource poor environments is solar drying, which is often done in the open air where the product is exposed directly to the sun, but there is also the risk of contamination. Adding value through improved solar drying is a proven way to stabilize the product and extend postharvest life for consumption and marketing, diversify and increase income, and develop new markets. Many designs have been proposed for improved solar dryers, but few have been adopted, either because they provide little improvement in drying rates over open-air drying, or because they are too costly to use in the developing world. The most common improved solar dryer is the cabinet dryer. Although cabinet dryers are more effective than open air drying, they are inherently inefficient and can only handle relatively small quantities of product. We have designed a novel dryer that can be constructed inexpensively from local materials, has significantly higher airflow rates, and therefore greatly reduced drying times. A raised drying bed is covered with black plastic. Product on mesh drying trays is placed on the drying bed and covered with clear plastic. The plastic is connected to a chimney at one end of the drying bed. The heated air in the covered tunnel is drawn over the drying product by the draft up the chimney. The chimney dryer significantly reduced drying times in comparison to air drying or drying in a cabinet dryer. The chimney provides a measure of temperature control – as temperatures in the tunnel rise, air speed increases, moderating the temperature increase. The advantages of the dryer include a relatively high capacity, and a flexible design that can be modified to suit the needs of the product and the user.

Keywords: solar, dryer, food losses, low cost

INTRODUCTION

Growing fruits and vegetables is highly profitable for both small- and large-scale farmers in the developing world. These crops are often harvested in high volumes over a short period of time; at peak harvest times quality is high but prices are low. In the developing world, loss and waste of fresh produce can be very high since farmers lack the cool storage infrastructure required to extend product life. Solar drying of fresh fruits and vegetables is a simple processing technique that adds value to crop surpluses, preserves and extends food supplies, empowers smallholders and creates rural employment. It is also the most common method used to preserve agricultural products in most tropical and subtropical countries (Szulmayer, 1971). Usually, products are dried in the open air and thus are unprotected from rain, dirt and dust as well as infestation by insects, rodents and other animals (Ekechukwu and Norton, 1999). Consequently, food quality may degrade to such an extent that it may render products unsafe or inedible.

The resulting loss of food quality in dried products has negative economic effects for both domestic and international markets. Protected solar dryers provide more rapid,



uniform and hygienic drying (Doymaz and Pala, 2002; Karathanos and Belessiotis, 1997). The most common such dryer is the cabinet dryer, which includes a compartment for solar heating of incoming air that then flows convectively through produce on trays in the drying cabinet. Indirect solar drying cabinets were invented in the 1970s and promoted by the FAO in the 1980s to overcome problems of open-air drying. The standard design uses a wooden frame, a glass or plastic sheet for the solar collector, and a double walled cabinet (made of wood, metal or a plastic covered wooden frame) with a short pipe for a chimney (FAO, 1985).

This design has some intrinsic disadvantages: as the air rises through the produce it cools and increases in humidity. This means that produce on lower trays dries much more rapidly than product on the top trays, and tends to reduce the rate of convection. In addition, cabinet dryers are rather complex and expensive to construct.

We have designed a novel solar dryer, the “UC Davis Chimney Dryer”, constructed from inexpensive and readily available materials to overcome disadvantages of other solar dryer designs. The dryer provides efficient drying even in overcast or partially cloudy conditions. It requires no electricity and is self-regulating with respect to temperature. In this paper we describe the construction of the dryer and the results of preliminary tests comparing the functionality of the new dryer with that of a typical cabinet dryer.

MATERIALS AND METHODS

The UC Davis solar chimney dryer comprises a clear plastic tunnel enclosing a black absorber ‘table’ which is open at one end. A 2-m chimney at the other end draws solar-heated air over the product, which is placed on drying trays on the table at the top of the tunnel. The design is flexible enough to accommodate a variety of products from whole apricots to smaller items such as sliced tomatoes or mangoes. The drying trays can be built to almost any size depending on the product to be preserved, as long as the drying table also accommodates the change in tray size.

Construction

The dryer is built from low-cost materials easily available material in local markets around the world. Typical materials needed for the drying bed, the chimney and the trays are described in Table 1.

Table 1. Materials needed to construct a solar dryer.

Item description and specification	Unit	Quantity
Clear polyethylene plastic for chimney (2.2×2.6 m) and dryer bed (4×2 m), greenhouse grade plastic, thickness 0.10-0.15 mm (4-6 mL)	m ²	14
Black plastic or weed cloth for dryer bed (6.0×2.7 m, thicker is better)	m ²	17
Plastic mesh for 10-0.6 m × 0.6 m trays	m ²	4
Wood for bed frame and chimney (3.5×3.5 cm)	m	71
Wood for 10 trays (2×4 cm)	m	27
2×0.6 m (0.64×3.74 cm) wood lath to secure the plastic to chimney	m	1.5
Fasteners (screws, nails, etc.)	As needed	

The four main components of the UC Davis Chimney Dryer are:

1. A drying bed covered in solid black material,
2. A chimney to create an air flow for faster drying, covered in plastic and with an opening at the height of the drying bed,
3. Mesh-covered drying trays to hold the produce placed on the drying bed, and
4. Clear polyethylene covering both the trays and drying bed and sealed to the chimney. Heated air passes horizontally above and below the produce on the drying trays.

1. Dimensions.

The dryer dimensions can be changed to meet various capacity needs. The key relationship is that the table should be as high as it is wide. The standard design uses 0.6×0.6 m trays. The table is 0.6 m high, and can accommodate 6 trays on a 4 m long table (Figure 1).

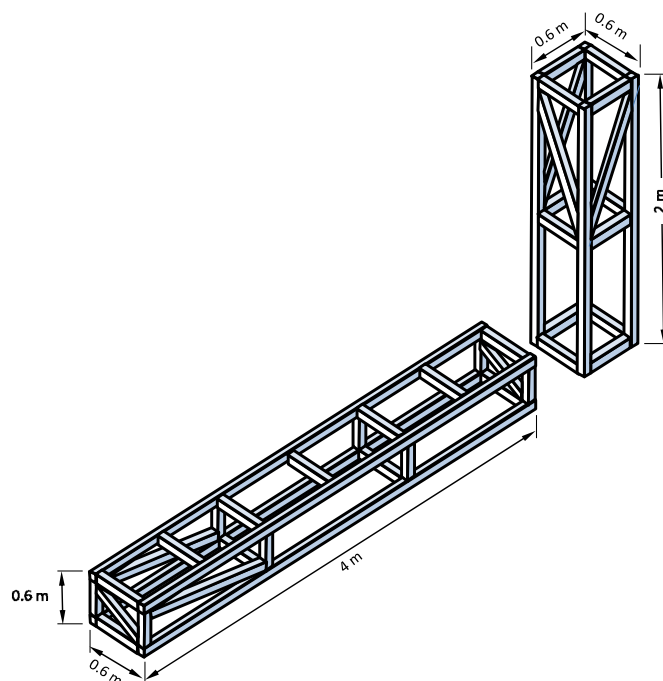

Figure 1. Orthographic design of UC Davis Chimney Dryer showing the wooden structure.

2. Site selection.

The dryer should be located on a flat site with good sun exposure. The opening of the dryer should always face the Equator, facing south in the northern hemisphere and north in the southern hemisphere.

3. Building the chimney.

The chimney is made up of four tall poles, and should rise at least 2 m above the top of the dryer table. The chimney should be as wide as the table and half as deep. The chimney can be anchored to the ground, or the poles can be hammered into the ground to stabilize it. The chimney can be stabilized with horizontal and diagonal struts. The whole chimney should be covered with plastic (clear or black), leaving the top open.

4. Building the table.

The table is the core of the dryer: the trays will be placed on it, and it is attached to the chimney. The frame can be built, or you can use an existing table or other similarly shaped structure. For the standard dryer the frame will be 4 m long and 60 cm tall. Using the materials listed above build a sturdy frame that can hold the weight of trays filled with product (Figure 2). Black plastic, or dark fabric is then stretched over the top sides, and ends of the table and stapled into place.

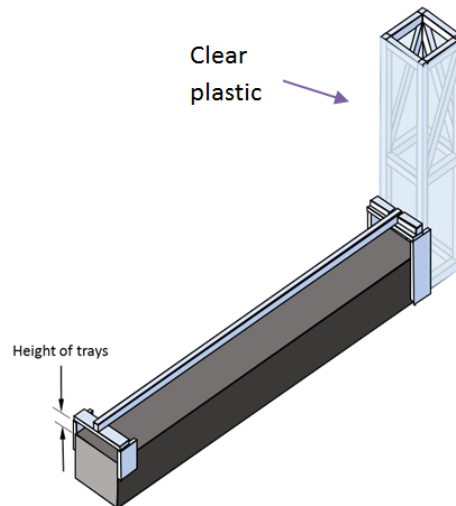

Figure 2. Orthographic design of dryer with drying table and chimney covered with plastic.

5. Building the trays.

Wooden strips 60 cm long are used to construct the trays. Each tray will use 4 pieces, one on each side. You can overlap the wood, or make the trays flat, either by edge jointing, or by constructing an overlapping joint. Food-grade mesh (plastic or stainless steel) is stapled to two opposite strips opposite then is tightened by pulling the strips apart and securing them to the other strips. The mesh is stapled along each edge to secure it to the wood (Figure 3).

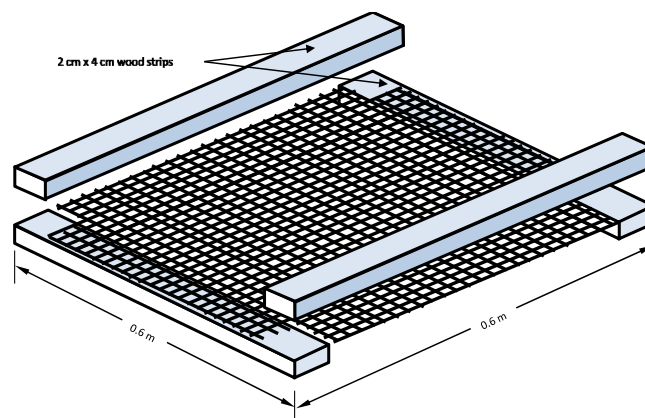

Figure 3. Orthographic design of the drying trays. It shows the correct way that wood strips and mesh should be placed.

6. Ensuring proper airflow.

To ensure adequate air-flow through the dryer, and to shed rain the top of the clear plastic sheet is held above the trays by a 4 m pole along the center of the table, which is held above the trays by wooden battens across the trays, and a support at each end of the table. A 4-m pole attached to each side of the plastic sheet provides tension on the sheet and allows it to be lifted easily off the trays to access the product as it dries. An opening is cut in the chimney, matching the space above the trays and below the table cover in the form of an arc or low triangle, starting from where the 4-m pole meets the chimney and down to the level of the drying table. Air will flow over the product, through this hole and up the chimney. It is critical that the plastic cover is joined to the chimney so that there are no leaks, which would

allow air to bypass the drying trays, and greatly reduce the efficiency of the dryer.

Initial assessment experiment

We compared the effectiveness of the chimney dryer with that of a traditional cabinet dryer under summer conditions in Davis, California. Mature tomatoes were sliced longitudinally with a maximum dimension of about 1-1.5 cm and placed on 0.6×0.6 m plastic mesh trays. Each tray held 0.45 kg of fresh sliced fruit. Ten trays were placed, two high, in the chimney dryer and five trays were loaded into the cabinet dryer. Samples of fruit were placed on small sections of plastic mesh and were weighed approximately every 2 h to monitor their moisture content. Inlet air and exhaust air temperatures were recorded for both dryers.

The test showed that the chimney dryer required only 2 days to bring the tomato moisture content to 10% (wet basis) compared with 5.5 days for the cabinet dryer. This was a result of the chimney dryer heating the air to a higher temperature and causing higher air speed past the fruit. The chimney dryer was much more cost effective than the cabinet dryer, with a cost of only \$ 7.33 kg⁻¹ day⁻¹ of drying capacity compared with \$ 26.66 kg⁻¹ day⁻¹ for the cabinet dryer (Table 2).

Table 2. Comparison of construction, operating costs and efficiency of chimney vs. traditional cabinet dryer at the initial assessment experiment in 2012.

	Chimney dryer	Cabinet dryer
Capital cost (\$)	38.93	58.84
Fruit capacity, fresh weight (kg)	4.5	2.25
Time to dry fruit to 10% MC (11-h days)	2.0	5.5
Cost per drying capacity (\$ kg ⁻¹ day ⁻¹)	7.33	26.66
Average air temperature leaving dryer – ambient (°C)	15.2	9.3
Air velocity past fruit (m s ⁻¹)	0.63	0.11

Both dryers caused blackening of some of the dried fruit. Perhaps because of its higher drying temperature the blackening was greater in the chimney dryer. However, the drying air temperatures in both dryers were within the typical operating range of small-scale fruit and vegetable dryers. These results show the potential for the UC Davis Chimney Dryer. The novel design achieves high airflow speeds in the drying tunnel that enhance the drying process and significantly reduce drying times.

DISCUSSION

Using the UC Davis Chimney Dryer

The following are important steps to consider when using the chimney dryer:

1. Testing the dryer.

A newly-constructed dryer should be tested to make sure that all the pieces fit together well, to ensure that there are no leaks or gaps in the plastic and to measure the temperature (if possible) at different locations within the dryer. If the dryer is working well, strips of tissue paper hanging from the center pole under the clear plastic will flutter, the tunnel roof will be concave (due to suction from the chimney), and there will be shimmering at the top of the chimney's shadow.

2. Preparing the product for drying.

Products should be rinsed in clean water prior to drying. Bulky products should be cut into pieces prior to loading onto trays. It is best to begin the drying process in the morning to give the maximum drying time before sunset.

3. Product size.

Thin items like herbs and leafy greens may dry in a few hours while large products like whole apricots or whole bananas will require several days to dry. You can decrease drying time by removing pits, peeling the product and/or cutting it into thin (6 mm) slices.

4. Loading the trays.

The trays of sliced fruit, vegetables, or other products, should be loaded so that the products do not overlap.

5. Pre-heating the air.

The first tray (furthest away from the chimney) should always be left empty. This is because the air entering the drying bed will need to be heated before it passes over the product.

6. Rotate trays.

For slow-drying product (whole fruits, thick vegetable slices) or under cloudy conditions, the trays may need to be rotated once or twice each day, moving the trays closest to the chimney further away and the furthest trays close to the chimney. This is because the air closest to the chimney is warmer than the air closer to the inlet. Rotating trays and leaving an open preheating area provides a more uniformly dried product.

7. Keep the plastic taut.

The clear plastic should not touch the fresh product so it should be taut, creating a tent over the product and trays. Attaching the sides of the plastic to a pole makes it easier to ensure that the plastic stays taut.

Conditions that affect dryer performance

In our tests we found that there were several factors that affected the dryer performance:

1. Air temperature.

High air temperature reduces relative humidity and speeds drying. However, air temperatures that are too high could reduce quality of the dried product; dark color, bleaching, and decreased storage life are typical effects of excessive drying temperatures. Most fruits and vegetables should be dried with maximum air temperatures in the range of 60-65°C, but there are exceptions. For cabbage, onions and leafy greens, the maximum air temperature is 57°C. Nuts and grains have a maximum temperature of about 54°C although walnuts should not be dried above 43°C. Operators should regularly monitor air temperatures at the entrance to the chimney. An inexpensive dial or digital thermometer works well for this. One of the innate advantages of the chimney dryer is that the system is self-regulating. As solar radiation increases drying temperatures, airflow up the chimney will increase, preventing excessive drying temperatures. If temperatures in the drying area are too high, check airflow, and, if necessary, lift the tensioning pole to open the bottom of the clear plastic, thus allowing more air into the dryer.

2. Stacked trays.

The dryer can be used with two or more trays stacked on top of each other (with blocks between the trays). Because air temperatures will be higher at the top of the drying bed, the top trays will dry faster than the lower trays. Rotate tray positions once or twice during the drying process. Rotating trays may also reduce bleaching, an effect of direct solar radiation that may be undesirable. Bleaching may also be reduced by covering the top trays with a light shade cloth.

3. Airspeed.

Air flowing past the product is essential for moisture removal. Thin strips of tissue

paper or a small piece of ribbon taped to the center pole provide a good indication that air is moving through the dryer. Inadequate flow (tissue paper is not moving, temperatures are excessive) suggests that the air entrance is blocked or covered in some way. A 50-75 mm headspace above the product at the center of the tunnel is enough to provide free flow of air while ensuring high air speeds over the product. Puffing smoke from a bee smoker is another good way of observing airflow through the dryer.

4. Humidity.

Low air humidity speeds drying. Heating air reduces its humidity and even in locations with high ambient humidity the drier heats air enough to produce the low humidity required for rapid drying.

5. Adverse weather conditions.

The dryer works in cloudy bright to sunny conditions, and even occasional rain showers are not a problem. However, drying should not be attempted during periods of continuous rain or heavy clouds (more than one day).

6. Amount of product on trays.

Adding more product to the trays increases the overall amount of product dried day⁻¹, but it may also increase drying times. Full trays of leafy greens and herbs weigh less than 2.5 kg m⁻² and dry in less than one day. Fruit slices or halves may take two or more days to dry. It is possible to modify the dryer to hang grapes inside for drying in bunches. Recent tests showed complete drying in about 5 to 7 days at a loading of 50 kg m⁻².

Storing dried product

Properly dried fruits and vegetables can be stored for several months to a year. Dried foods should be stored in a cool, dry and dark area. After drying, the product should be allowed to cool and then packed into dry, moisture-tight containers (plastic or glass container with screwcap lid or plastic bags with top folded over several times). A cool temperature is the most important factor in storing dried product: the higher the temperature, the faster the product will deteriorate.

Fruit should be dried to approximately 20% moisture content: this means that the fruit will still be pliable. Vegetables should be dried to 10% moisture: a properly dried vegetable will be brittle and will snap if bent. An alternative method for determining safe product moisture content is to measure the relative humidity of the air in the storage container. The humidity should be less than 65%, which will not allow mold to grow.

Different uses of the UC Davis Chimney Dryer

The UC Davis Chimney Dryer has been tested in many different areas of the world through international aid projects testing low cost technologies that could reduce postharvest losses. The flexibility of the dryer's design has allowed modifications to suit the drying needs of each community. In Uzbekistan (Central Asia), apricot drying is a big business leading to significant exports to the neighbouring former Soviet Union countries. The UC Davis Chimney Dryer has been tested and proven successful in producing dried apricots of high quality.

Grape drying for raisin production in the former Soviet Union is done by hanging whole grape clusters under the sun to produce round raisins (unlike the flat raisins dried on the ground that are accepted in the West). In Uzbekistan, the UC Davis Chimney Dryer tunnel was modified to allow grape clusters to be hung in the tunnel. This strategy led to faster and more uniform drying of raisins in comparison to the traditional technique.

In Bangladesh, small fish are dried outdoors on woven bamboo trays. Insect contamination is a problem that is addressed with the use of insect repellents or insecticides. Drying fish in the chimney dryer is not only more efficient, but also appears to eliminate the need for chemical treatment. The air movement into the tunnel means that the insects cannot detect the product.

Literature cited

Doymaz, I., and Pala, M. (2002). Hot-air drying characteristics of red pepper. *Food Eng.* 55 (4), 331–335 [https://doi.org/10.1016/S0260-8774\(02\)00110-3](https://doi.org/10.1016/S0260-8774(02)00110-3).

Ekechukwu, O.V., and Norton, B. (1999). Review of solar-energy drying systems II: an overview of solar drying technology. *Energy Convers. Manage.* 40 (6), 615–655 [https://doi.org/10.1016/S0196-8904\(98\)00093-4](https://doi.org/10.1016/S0196-8904(98)00093-4).

Food and Agricultural Organization (FAO). (1985). *Expert Consultation on Planning the Development of Sun-Drying Techniques in Africa* (Rome, Italy: Food and Agricultural Organization of the United Nations).

Karathanos, V.T., and Belessiotis, V.G. (1997). Sun and artificial air drying kinetics of some agricultural products. *Food Eng.* 31 (1), 35–46 [https://doi.org/10.1016/S0260-8774\(96\)00050-7](https://doi.org/10.1016/S0260-8774(96)00050-7).

Szulmayer, W. (1971). From sun drying to solar dehydration: I - methods and equipment. *Food Aust.* 23, 440–443.